



## OP-MX2885S1MD-0.3

### X2 SR Transponder, 300m Reach

#### Features

- ◆ Compatible with X2 MSA Rev2.0b
- ◆ Support of IEEE 802.3ae 10GBASE-SR at 10.3125Gbps
- ◆ Transmission Distance up to 300m(MMF)
- ◆ Vertical Cavity Surface Emitting Laser at 850nm
- ◆ SC Duplex Optical Connector
- ◆ Hot Pluggable 70-PIN Connector with XAUI Electrical Interface
- ◆ Management and control via MDIO 2-wire interface
- ◆ Power Supply :+3.3V, APS(+1.2V)
- ◆ Diagnostic Optics Monitoring
- ◆ Temperature Range: 0~ 70 °C
- ◆ ROHS6 Compatible



#### Applications

- ◆ 10GE Ethernet switches and routers
- ◆ 10GE Core-routers
- ◆ 10GE Storage
- ◆ Other 10Gbps Ethernet Transmission System

#### Absolute Maximum Ratings

Parameter	Symbol	Min	Max	Unit	Ref.
Storage Ambient Temperature Range		-40	+85	°C	non condensing
Powered case Temperature Range		0	+70	°C	non condensing
Adaptable Power Supply (APS)	Vapsense	0	1.5	V	Voltage @ Pin APS Sense
Supply Voltage Range @ 3.3V	Vcc3	-0.5	4.0	V	

Any stress beyond the maximum ratings can result in permanent damage. The device specifications are guaranteed only under the recommended operating conditions.

### Operating Conditions

Parameter	Symbol	Min	Typical	Max	Unit
Operating Case Temperature	Tc	0		+70	°C
Power Supply Voltage	V <sub>CC3</sub>	3.14	3.3	3.47	V
	V <sub>APS</sub>	1.152	1.2	1.248	
Power Dissipation	PD		1.7	2.4	W

### Transmitter Characteristics

Parameter	Symbol	Min.	Typ.	Max.	Unit	Note
Operating Range				300	m	
Operating Data Rate			10.3125		Gb/s	
Average Optics Power	P <sub>o</sub>	-6.5		-1	dBm	
Input Centre Wavelength	$\lambda$	840	850	860	nm	
Spectral Width	$\Delta \lambda$		0.4	0.45	dB	
Extinction Ratio	ER	3.5				
Optical Modulation Amplitude	OMA	525			$\mu$ W	
Transmitter and Dispersion Penalty	TDP			3.2	dB	

### Receiver Characteristics

Parameter	Symbol	Min.	Typ.	Max.	Unit	Note
Operating Data Rate			10.3125		Gb/s	
Average Receiver Power	P <sub>o</sub>	-9.9		-1.0	dBm	
Sensitivity in OMA	OMA <sub>0</sub>			-11.1	dBm	1
Stressed Sensitivity in OMA	OMA <sub>st</sub>			-7.5	dBm	

**Note :**

1. Measured at 10.3125Gb/s,Non-framed PRBS2^31-1,NRZ

**XAUI I/O Characteristics**

Param	Symbol	Min.	Typ.	Max.	Unit	Note
XAUI Data Rate	DR		3.125		Gb/s	
XAUI Baud Rate Tolerance		-100		+100	ppm	Relative Tolerance
Differential Input Voltage Swing		220		1600	mv	8B/10B Coded Input Signal
Differential Output Voltage Swing		800		1600	mVp-p	RLOAD = 100Ω ± 5%
Differential Input Impedance		80	100	120	Ω	
Total Output Jitter	TJXAUI			0.35	UI	no pre-equalization
Total Deterministic Output Jitter	DJXAUI			0.17	UI	no pre-equalization

**Signal Specifications – Electrical**

Parameter	Symbol	Min	Typ	Max	Units
1.2 V CMOS					
Input High Voltage	VIL(MAX)	-	-	0.36	V
Input Low Voltage	VIH(MIN)	0.84	-	1.25	V
Capacitance		-	-	320	pF
Pull Up Resistance	Rpull	4.7k	10k	22k	ohm
MDIO I/O					
Output Low Voltage	VOL	-0.3	-	0.2	V
Output Low Current	IOL	-	-	4	mA
Input High Voltage	VIH	0.84	-	1.5	V
Input Low Voltage	VIL	-0.3	-	0.36	V
Pull-up Supply Voltage	VPULL	1.14	1.2	1.26	
Input Capacitance	CIN	-	-	10	Pf
Load Capacitance	CLOD	-	-	470	Pf
External Pull-up Resistance	EPULL	200	-	-	Ohm

**Pin Definitions**

Pin No	Name	Dir	Function	Notes
1	GND		Electrical Ground	1
2	GND		Electrical Ground	1
3	GND		Electrical Ground	1
4	5.0V		Power	2
5	3.3V		Power	2
6	3.3V		Power	2
7	APS =1.2V		Adaptive Power Supply	2
8	APS =1.2V		Adaptive Power Supply	2
9	LASI		Open Drain Compatible 10K-22K pull up on host. Logic High: Normal Operation Logic Low: LASI Asserted	3
10	RESET	I	Open Drain compatible. 10-22K pull-up on transceiver Logic high = Normal operation Logic low = Reset Minimum reset assert time 1 ms	3
11	VEND SPECIFIC		Vendor Specific Pin. Leave unconnected when not in use.	6
12	TX ON/OFF	I	Open Drain compatible. 10-22K pull-up on transceiver Logic high = Transmitter On (capable) Logic low = Transmitter Off (always)	3
13	RESERVED		Reserved	3
14	MOD DETECT	O	Pulled low inside module through 1k	
15	VEND SPECIFIC		Vendor Specific Pin. Leave unconnected when not in use.	6
16	VEND SPECIFIC		Vendor Specific Pin. Leave unconnected when not in use.	6
17	MDIO	I/O	Management Data IO	3, 4
18	MDC	I	Management Data Clock	3, 4
19	PRTAD4	I	Port Address Bit 4 (Low = 0)	3
20	PRTAD3	I	Port Address Bit 3 (Low = 0)	3
21	PRTAD2	I	Port Address Bit 2 (Low = 0)	3
22	PRTAD1	I	Port Address Bit 1 (Low = 0)	3
23	PRTAD0	I	Port Address Bit 0 (Low = 0)	3
24	VEND SPECIFIC		Vendor Specific Pin. Leave unconnected when not in use.	6
25	APS SET		Feedback input for APS	
26	RESERVED		Reserved for Avalanche Photodiode use.	6
27	APS SENSE		APS Sense Connection	
28	APS =1.2V		Adaptive Power Supply	2

29	APS =1.2V		Adaptive Power Supply	2
30	3.3V		Power	2
31	3.3V		Power	2
32	5.0V		Power	2
33	GND		Electrical Ground	1
34	GND		Electrical Ground	1
35	GND		Electrical Ground	1
36	GND		Electrical Ground	1
37	GND		Electrical Ground	1
38	RESERVED		Reserved	
39	RESERVED		Reserved	
40	GND		Electrical Ground	1
41	RX LANE0+	O	Module XAUI Output Lane 0+	5
42	RX LANE0-	O	Module XAUI Output Lane 0-	5
43	GND		Electrical Ground	1
44	RX LANE1+	O	Module XAUI Output Lane 1+	5
45	RX LANE1-	O	Module XAUI Output Lane 1-	5
46	GND		Electrical Ground	1
47	RX LANE2+	O	Module XAUI Output Lane 2+	5
48	RX LANE2-	O	Module XAUI Output Lane 2-	5
49	GND		Electrical Ground	1
50	RX LANE3+	O	Module XAUI Output Lane 3+	5
51	RX LANE3-	O	Module XAUI Output Lane 3-	5
52	GND		Electrical Ground	1
53	GND		Electrical Ground	1
54	GND		Electrical Ground	1
55	TX LANE0+	I	Module XAUI Input Lane 0+	5
56	TX LANE0-	I	Module XAUI Input Lane 0-	5
57	GND		Electrical Ground	1
58	TX LANE1+	I	Module XAUI Input Lane 1+	5
59	TX LANE1-	I	Module XAUI Input Lane 1-	5
60	GND		Electrical Ground	1
61	TX LANE2+	I	Module XAUI Input Lane 2+	5
62	TX LANE2-	I	Module XAUI Input Lane 2-	5
63	GND		Electrical Ground	1
64	TX LANE3+	I	Module XAUI Input Lane 3+	5
65	TX LANE3-	I	Module XAUI Input Lane 3-	5

66	GND		Electrical Ground	1
67	RESERVED		Reserved	
68	RESERVED		Reserved	
69	GND		Electrical Ground	1
70	GND		Electrical Ground	1

Notes:

- 1) Ground connections are common for TX and RX.
- 2) All connector contacts are rated at 0.5A nominal.
- 3) 1.2V CMOS compatible.
- 4) MDIO and MDC timing must comply with IEEE802.3ae, Clause 45.3
- 5) XAUI output characteristics should comply with IEEE802.3ae Clause 47.
- 6) Transceivers will be MSA compliant when no signals are present on the vendor specific pins.

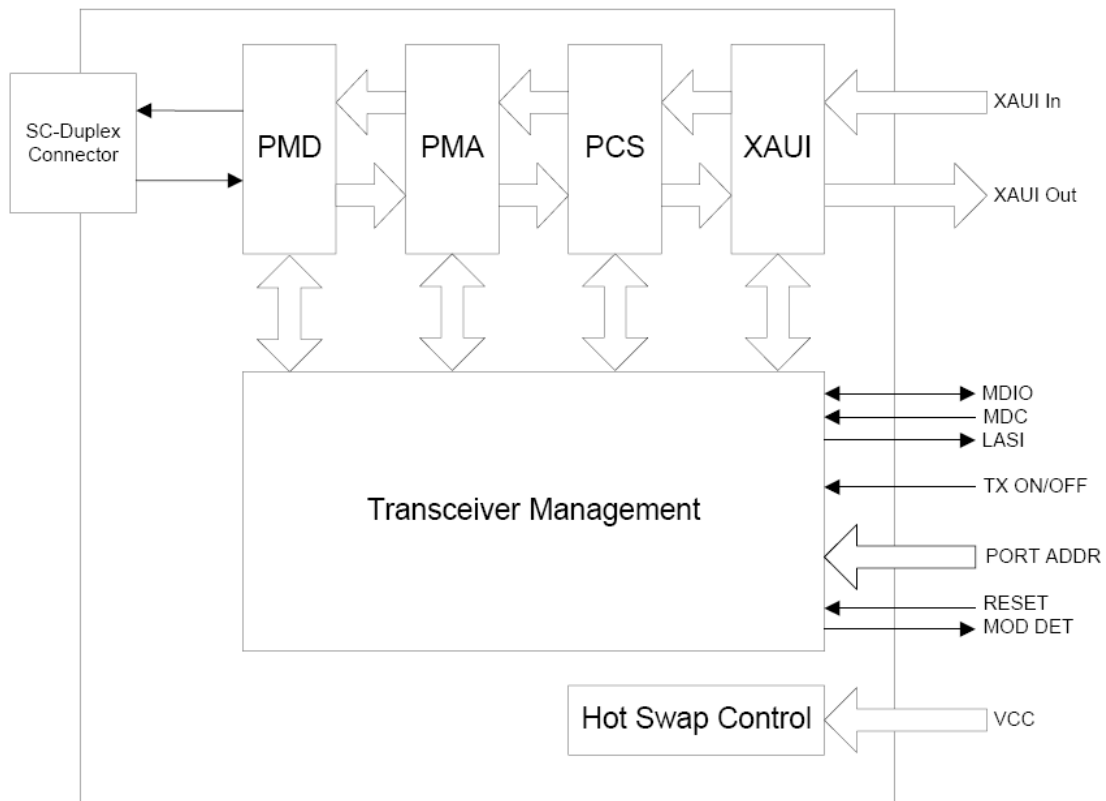

**Figure1.** Functional Diagram of Typical X2 Style Transceiver

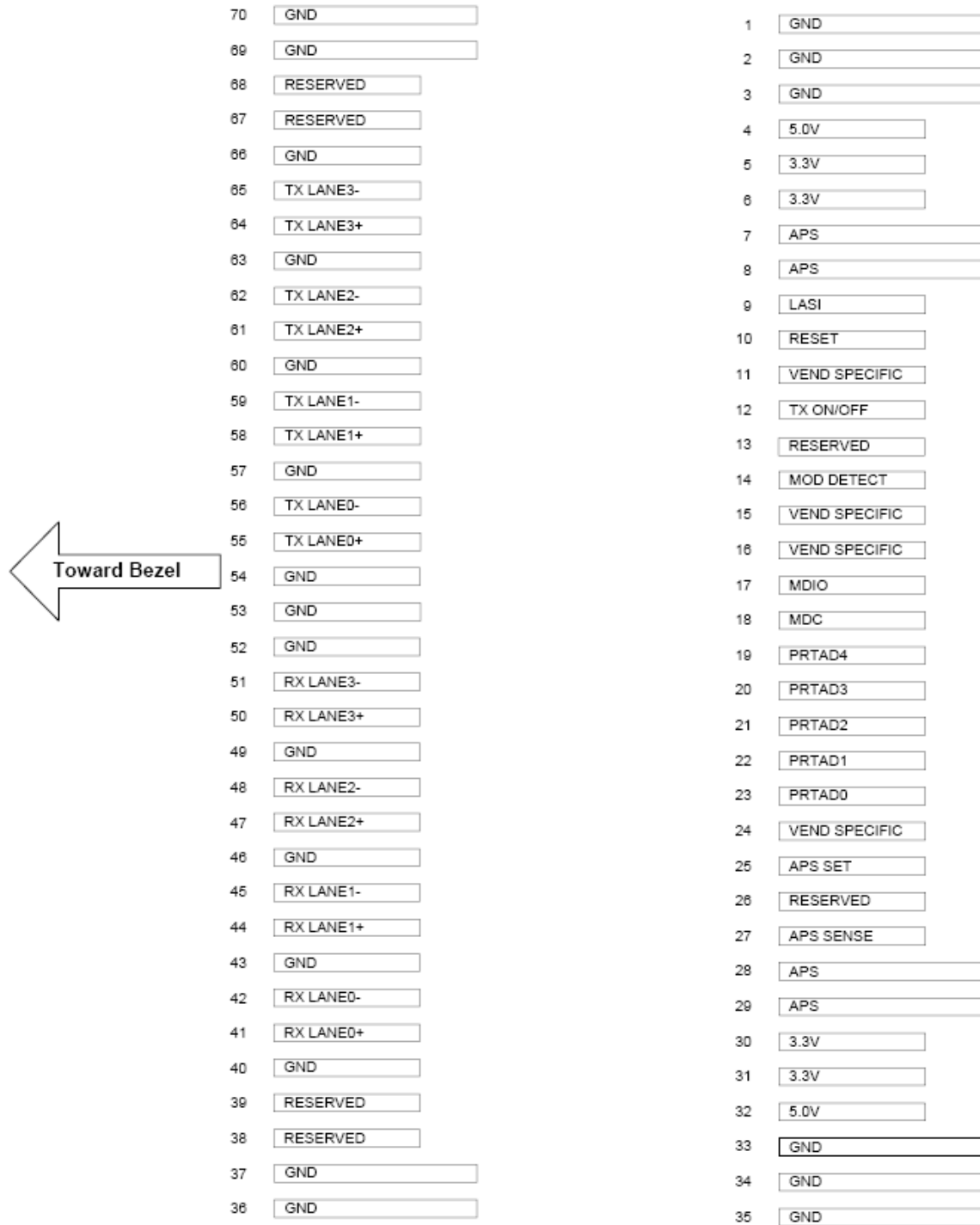
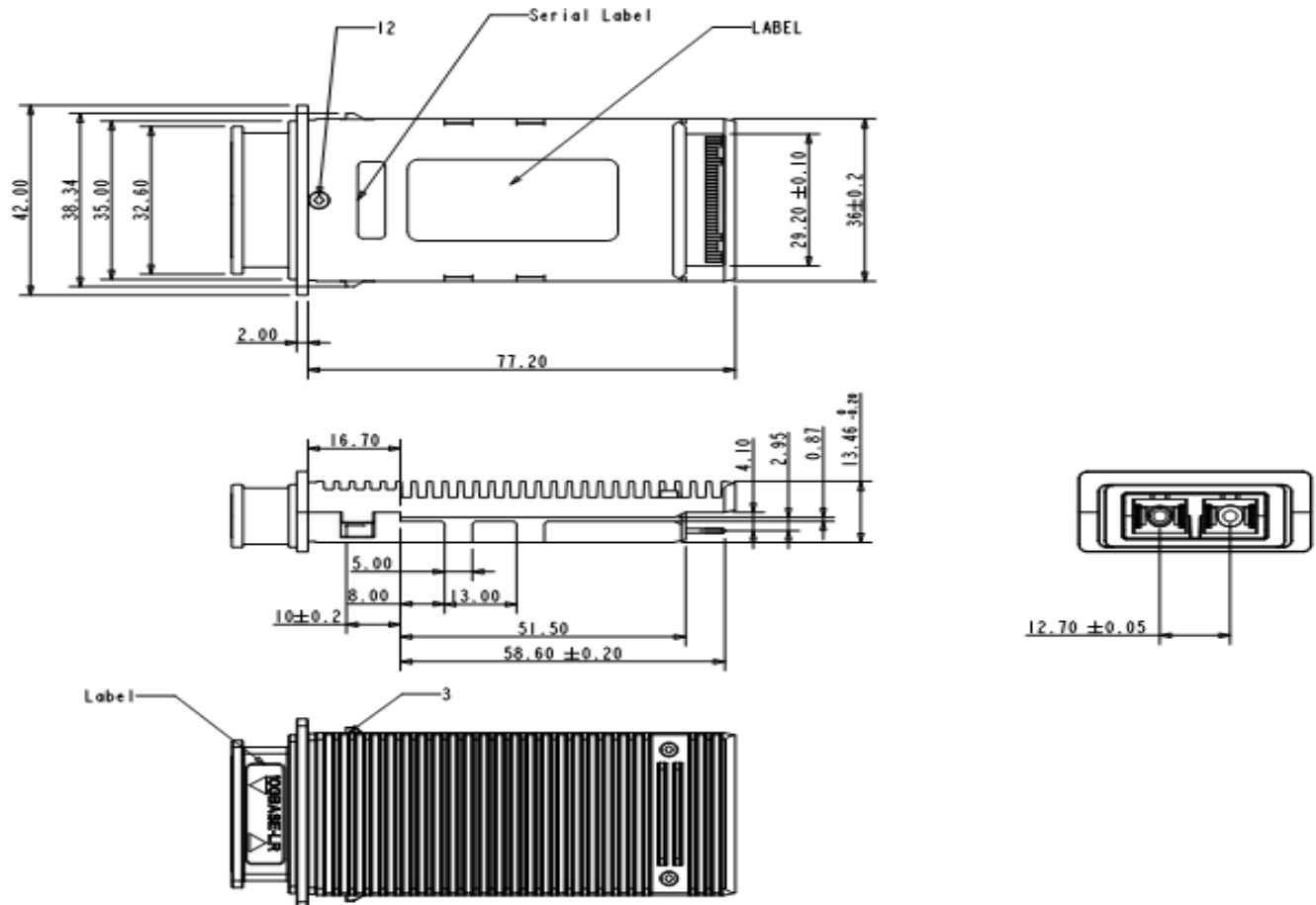

Figure2.Electrical Pin-out Details



Dimensions in mm

**Figure3.** Mechanical Dimensions



**Regulatory Compliance**

OPTOSTAR X2 Transponder is designed to be Class I Laser safety compliant and is certified per the following standards:

Feature	Agency	Standard	Certificate / Comments
Laser Safety	FDA	CDRH 21 CFR 1040 and Laser Notice No. 50	1120291-000
Product Safety	UL	UL and CUL EN60950-2:2007	WT10093765-D-E-E
Environmental protection	SGS	RoHS Directive 2002/95/EC	GZ1001008706/CHEM
EMC	WALTEK	EN 55022:2006+A1:2007 EN 55024:1998+A1+A2:2003 -	WT10093768-D-E-E

**Ordering information**

Number	Product Description
OP-MX2885S1MD-0.3	850nm, 10.3125Gbps, X2 300m, 0°C ~ +70°C

**Important Notice**

Performance figures, data and any illustrative material provided in this data sheet are typical and must be specifically confirmed in writing by OPTOSTAR before they become applicable to any particular order or contract. In accordance with the OPTOSTAR policy of continuous improvement specifications may change without notice.

The publication of information in this data sheet does not imply freedom from patent or other protective rights of OPTOSTAR or others. Further details are available from any OPTOSTAR sales representative.